

IF IN DOUBT - ASK

ALL DIMENSIONS SHOWN IN mm

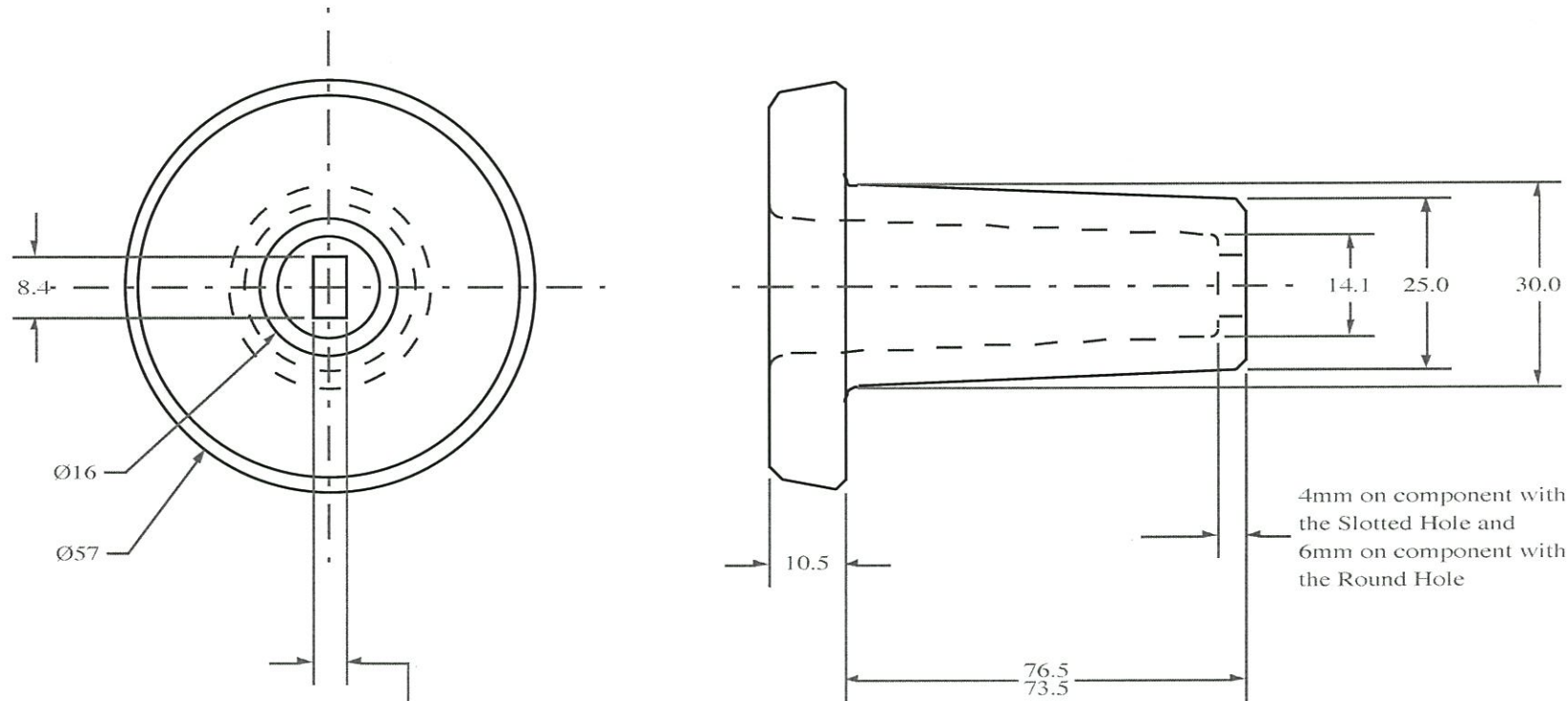

Overall Tolerance is 4.9 +/- 0.3
When manufacturing please aim for the dimension to be 4.7 to 5.1mm

NOTES
Slotted Hole
Part No. 47875

Round Hole
Part No.47875R
Round Hole Ø7mm

DESCRIPTION
Cup Lock
Anchor

MATERIAL
Anchor
Refractory

DRAWING NUMBER
47875

DATE DRAWING ISSUED 15/05/05 ISSUE 1

SCALE SHEET
NTS 1 of 1 A4

THIRD ANGLE PROJECTION

DO NOT SCALE	READ ALL NOTES BEFORE STARTING WORK	DATE DRAWING ISSUED	15/05/05	ISSUE	1
		SCALE	NTS	SHEET	1 of 1